

# HUSKY SAFE-T-BREAK® VALVES

## DIESEL EXHAUST FLUID

Husky Diesel Exhaust Fluid (DEF) Safe-T-Break® valves stop the flow of fluid on both sides of the separation.

### Model #7219

- Non-reconnectable Safe-T-Break®.
- Low profile design.
- Thread sealant not required with BSPP threads.
- 100% DEF compatible parts.
- Instant-closing, dual poppet check valve design.
- Maximum separation of 300 lbf / 1334.5 N.
- Comes standard with guard.

### Model #7204

- For use on non-electrically conductive installation.
- Low profile design.
- Non-Reconnectable Safe-T-Break®.
- Light weight construction.
- 100% DEF compatible parts.
- Instant closing, dual poppet check valve as Model #7219.
- Maximum separation of 300 lbf / 1334.5 N.
- Comes standard with guard.

## SPECIFYING INFORMATION

Model Number	Description	Weight lbs.(kg.)
7219	1" M x 1" M Stainless Steel Non-Reconnectable Safe-T-Break®	0.90 (.40)
7204	1" M x 1" M High Density Polyethylene (HDPE) Safe-T-Break®	0.15 (.06)

## CONSTRUCTION

### Body

Model #7219 = Stainless Steel

Model #7204 = High Density Polyethylene (HDPE)

Seals Fluorocarbon

Inlet 1" / 25.4 mm BSPP

Part #7219



Part #7204



## PATENTS

Patent Numbers: Pending



MADE IN THE U.S.A.

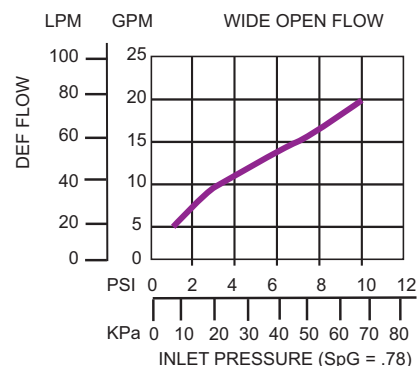

# HUSKY SAFE-T-BREAK® VALVES

## DIESEL EXHAUST FLUID

- **Dimensions**
- **Accessories**

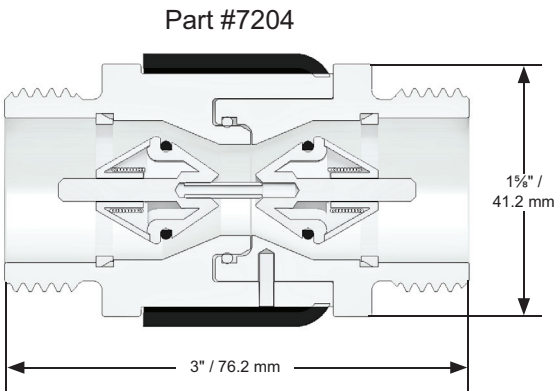
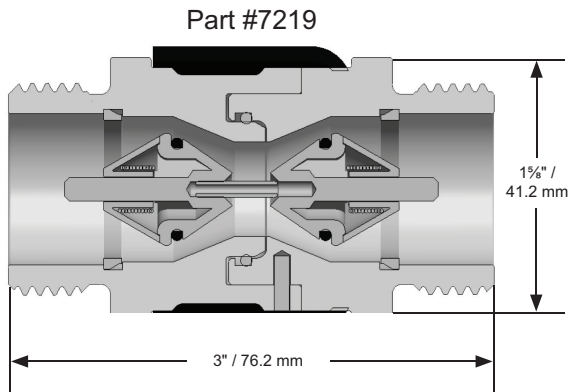

### Guards

Model No.	Description
7224	Black Scuff Guard
6503	Dispenser Scuff Guard

### Adaptors

Model No.	Description
7282	1" M x 1" M BSPP Adaptor
7356	1" M BSPP X M M34 Adaptor

### DEF Seal Kits

Model No.	Description
7523	1" BSPP Seal Kit Assembly

DIESEL EXHAUST FLUID

