

# PACIFIC GAUGE



**New from Oct 2011**

## I-A Husky Nozzle

**New from Oct 2011**

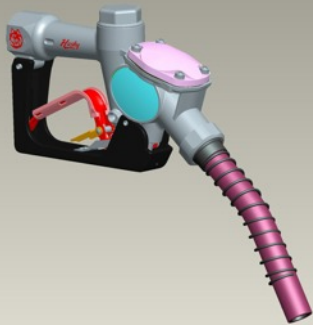

**DOUBLE POPPET BSPP, Auto Diesel, Black 1/2 grip guard,**

- With the new Stream Shaper Spout for Diesel

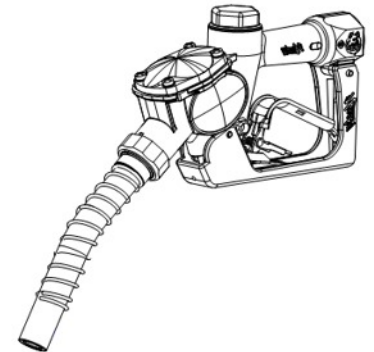

### Husky 1 A

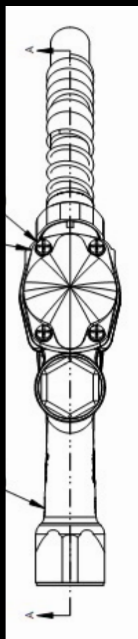

Mid range flow for Trucks and Cars with a strong 70ltrs/m

Trucks and Cars can both use our 1-A Nozzle on new Diesel Fill Neck Configurations

The Husky Stream Shaper

- Helps Keep Flows High
- Reduce Clicking off's
- Reduces Diesel from foaming

Cars, Vans, Ute's can still use truck lanes for high flow

### Protection against incorrect refuelling

The protection against incorrect refuelling feature ensures that Diesel fuel tanks cannot be filled with gasoline. only a fuel nozzle with a diameter of approximately 24 mm can fit.

- The Husky diesel fuel nozzle has the correct diameter for the new fill neck configurations.
- To reduce the chance that gasoline is mistakenly used to fuel a Diesel Vehicle/ or Truck, a protection system has been installed, With most new Diesel Vehicles & Trucks now standardized.
- ULP nozzles are 21 mm in diameter while a standardized low flow diesel fuelling nozzles are 24 mm.

If a nozzle smaller than the correct 24 mm diesel nozzle is used, a flap stays closed and prevents filling your Diesel Car or Truck with gasoline.

The misfueling protection won't let the flap open unless the correct 24 mm diameter diesel nozzle contacts two release buttons and releases the flap lock

### Cleaner Customers:

Diesel will not evaporate like ULP;

Hose pressure will not increase the amount of Diesel in our Husky spouts.

The Husky poppet is forced closed w/ pressure

- Increased hose pressure in some nozzles can cause the diesel to leak onto your new customers that may have just brought a new diesel car.
1. With our 1-A DP you can have it both ways.
    - Trucks can fill at up to 70ltrs/m
    - 4x4's & Cars can still use your truck bowsers at up to 80ltrs/m w/new fill necks
  2. Stream Diesel Shaper helps to stop Clicking off's & Foaming for faster filling

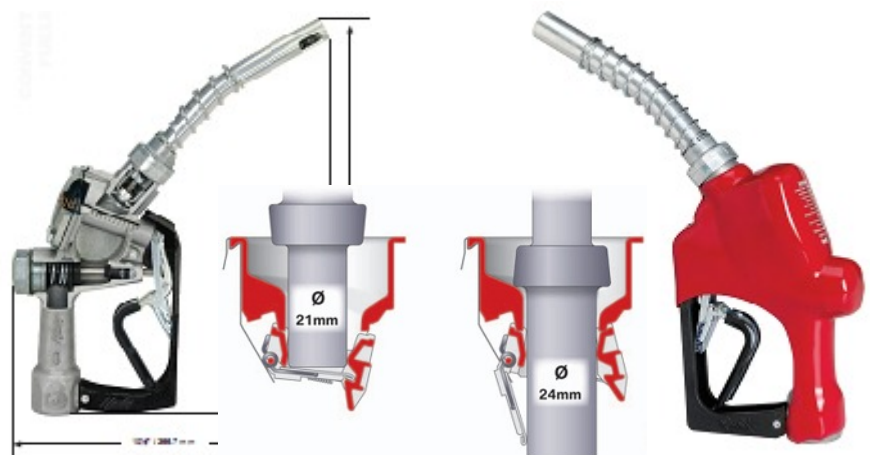

**PacificGauge**  
The Level People

# HUSKY 1A NOZZLE

## AUTOMATIC NOZZLE

Automatic shut off-nozzle for full-service and self-service stations.

- 1A nozzle shuts off when the gas tank is full.
- Equipped with a unique Flo-Stop™ device that shuts off the nozzle if it falls from the fill tank or raises above the horizontal.
- Aluminum reinforced spout bushing keeps spout tip round and acts as a captive fastener to prevent tip-end sensor damage.

- *StreamShaper™* reduces turbulence for straighter fuel flow and less splash back spillage.
- Comes standard with smooth full grip guard.



### SPECIFYING INFORMATION

Model Number	Description	Shipping Weight lbs (kg)
<b><u>New Unleaded Nozzles w/ NPTF Threads:</u></b>		
209804	with Three Notch Hold Open Clip	3.3 (1.4)
209808	without Hold Open Clip	3.3 (1.4)
209859	with Three Notch Hold Open Clip and Reducer Bushing	3.3 (1.4)
209864	with Three Notch Hold Open Clip and 1808 Waffle Splash Guard	3.3 (1.4)
209872	with Three Notch Hold Open Clip, 1808 Waffle Splash Guard and Reducer Bushing	3.3 (1.4)
<b><u>New Unleaded Nozzles w/ BSPP Threads:</u></b>		
209816	with Three Notch Hold Open Clip	3.4 (1.5)
209820	without Hold Open Clip	3.4 (1.5)
<b><u>New Light Duty Diesel Nozzles w/ NPTF Threads:</u></b>		
209803	with Three Notch Hold Open Clip	3.4 (1.5)
209807	without Hold Open Clip	3.4 (1.5)
209861	with Three Notch Hold Open Clip and Reducer Bushing	3.4 (1.5)
209863	with Three Notch Hold Open Clip and 1808 Waffle Splash Guard	3.4 (1.5)
209873	with Three Notch Hold Open Clip, 1808 Waffle Splash Guard and Reducer Bushing	3.4 (1.5)
<b><u>New Light Duty Diesel Nozzles w/ BSPP Threads:</u></b>		
209815	with Three Notch Hold Open Clip	3.4 (1.5)
209819	without Hold Open Clip	3.4 (1.5)

### CONSTRUCTION

Body	Die cast aluminum body with black hand guard.
Seals	Fluorocarbon
Packing	Double o-ring seal protected by fiber reinforced Teflon
Lever	One piece contoured steel with hard plastic cover
Inlet	1" / 25.4 mm NPTF & BSPP

### LISTINGS

Listings: 

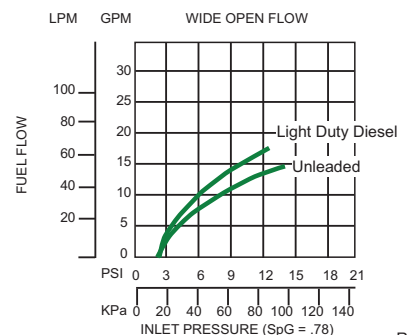

CONVENTIONAL FUELING

# HUSKY 1A NOZZLE

## AUTOMATIC NOZZLE

- **Dimensions**
- **Accessories**



### Safe-T-Breaks®

Model No.	Description
2276	1" F x 1" F NPTF Reconnectable Safe-T-Break®
5812	1" F x 1" F NPTF Non-Reconnectable Safe-T-Break®
6301	1" F x 1" F NPTF Non-Reconnectable PCC Safe-T-Break®
5231	1" F x 1" F NPTF Low Pull Reconnectable
3076	1" F x 1" F BSPP Reconnectable Safe-T-Break®
3076A	1" F x 1" F BSPP Reconnectable Safe-T-Break® - Atex
6914	1" F x 1" F BSPP Non-Reconnectable Safe-T-Break®

### Swivels

Model No.	Description
0087	1" M x 1" F NPTF Multi-Plane Swivel
0087W	1" M x 1" F NPTF Multi-Plane Swivel w/ Warm Weather Seals
4860	1" M x 1" F NPTF Multi-Plane High Flow Swivel
0095	1" M x 1" F NPTF 70° Pump Swivel
3395	1" M x 1" F NPTF Multi-Plane Restricted Swivel
0352	1" M x 3/4" F NPTF Multi-Plane Swivel
0356	1" M x 3/4" F NPTF Multi-Plane Swivel Anodized Black
3306	1" M x 1" F BSPP Multi-Plane Swivel
3306W	1" M x 1" F BSPP Multi-Plane Swivel w/ Warm Weather Seals
6949	1" M x 1" F BSPP Multi-Plane High Flow Swivel

### Swivel-Safe-T-Break® Combos

Model No.	Description
5969	1" M NPTF Multi-Plane Swivel connected to 1" F NPTF Reconnectable Safe-T-Break®
8015	1" M BSPP Multi-Plane Swivel connected to 1" F BSPP Reconnectable Safe-T-Break®

### Spouts

Model No.	Description
1473	Unleaded Spout w/o Flo-Stop™
1471	Light Duty Diesel Spout w/o Flo-Stop™

### Guards

Model No.	Description
0554	Full Grip Guard
6655	POPD Full Grip Guard
1804	Full Grip Reguard
7210	POPD™ Full Grip Nozzle Reguard
0226	Mate Nozzle Guard
	POPD™ Mate Guard w/ Clear Cover
1808	Waffle Splash Guard
0099	Protection Package
1811	Reguard Protection Package
6628	POPD™ Clear Cover
5494	Lever Guard
7376	Mate Handle Guard

### Testing and Maintenance Equipment

Model No.	Description
7089	Nozzle Service Kit
3593	Hold Open Clip Kit
0397	Unleaded Spout Gauge
0385	1" M x 3/4" F NPTF Reducer Bushing
1717	1" M x 3/4" F BSPP Reducer Bushing

